



高压、低功耗线性稳压器， 用于笔记本电脑

MAX8718/MAX8719

概述

MAX8718/MAX8719 是低功耗、8 引脚 TDFN 封装的线性稳压器，能够为高电池电压系统中的 CMOS RAM、实时时钟 (RTC) 和微控制器提供始终有效、不间断的供电电源。该电路由 100mA 线性稳压器和具有固定输出延时的电源就绪比较器 (PGOOD) 组成。关键特性包括：宽输入电压范围、低压差和低静态电源电流。

在保持低至 25 μ A (最大值) 的空载静态电流的条件下，MAX8718/MAX8719 还具有良好的输入电源和负载瞬态响应，并具有出色的 AC 电源抑制能力。即使输入电源从电池切换到 AC 适配器的过程中存在快速的电源电压变化，这些器件仍能提供稳定的 5V 或 3.3V 输出 (MAX8718)，或可调节的 1.24V 至 28V 输出 (MAX8719)。节省空间的 TDFN 封装具有较强的散热特性，可以耗散最大 1951mW 的功率。内部折返式限流和热关断电路使稳压器避免出现过载与过热故障。

除了笔记本电脑应用外，这些器件还可用于其它低功耗、高电压 ($4V < V_{IN} < 28V$) 设备中，例如智能电池、电流控制回路、电信应急电源，以及离线电源的内部管理电源。

MAX8718/MAX8719 采用热增强型 3mm x 3mm、8 引脚 TDFN 封装。

应用

CMOS/RTC 备用电源
微控制器电源
笔记本电脑
智能电池组
PDA 与手持终端
电池供电系统

特性

- ◆ 4V 至 28V 输入范围
- ◆ 18 μ A 静态电源电流
- ◆ 关断电源电流 $< 3\mu$ A
- ◆ 100mA 输出电流
- ◆ 由引脚选择 3.3V 或 5V 输出 (MAX8718)
- ◆ 可调节的 1.24V 至 28V 输出 (MAX8719)
- ◆ $\pm 2\%$ 输出精度
- ◆ 热过载保护
- ◆ 带有延时的电源就绪输出
- ◆ 热增强型 8 引脚 TDFN 封装

订购信息

PART	TEMP RANGE	PIN-PACKAGE	OUTPUT VOLTAGE
MAX8718ETA	-40°C to +85°C	8 TDFN 3mm x 3mm	3.3V/5V
MAX8719ETA	-40°C to +85°C	8 TDFN 3mm x 3mm	Adjustable

引脚配置

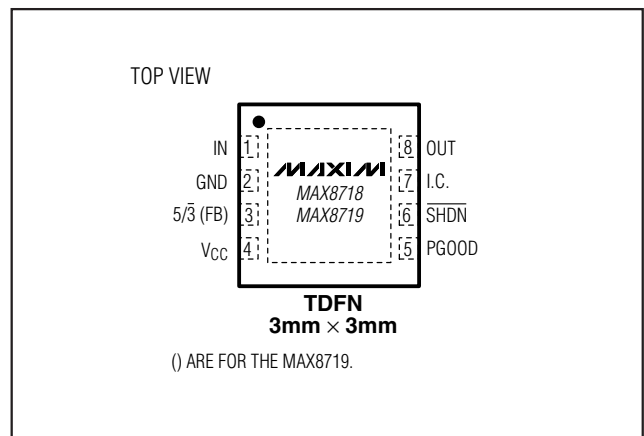

高压、低功耗线性稳压器， 用于笔记本电脑

MAX8718/MAX8719

ABSOLUTE MAXIMUM RATINGS

IN to GND-0.3V to +30V
 SHDN to GND-0.3V to (VIN + 0.3V)
 5/3 (MAX8718) to GND-0.3V to +6V
 FB (MAX8719) to GND-0.3V to +6V
 OUT (MAX8718) to GND-0.3V to +6V
 OUT (MAX8719) to GND-0.3V to +30V
 VCC to GND (MAX8718)-0.3V to +6V
 VCC to GND (MAX8719)-0.3V to +2.7V
 PGOOD to GND-0.3V to +30V

I.C. to GND-0.3V to +6V
 OUT Short Circuit to GND30s
 Continuous Power Dissipation (TA = +70°C)
 8-Pin TDFN (derate 24.4mW/°C above +70°C)1951mW
 Operating Temperature Range-40°C to +85°C
 Junction Temperature+150°C
 Storage Temperature Range-65°C to +150°C
 Lead Temperature (soldering, 10s)+300°C

Stresses beyond those listed under "Absolute Maximum Ratings" may cause permanent damage to the device. These are stress ratings only, and functional operation of the device at these or any other conditions beyond those indicated in the operational sections of the specifications is not implied. Exposure to absolute maximum rating conditions for extended periods may affect device reliability.

ELECTRICAL CHARACTERISTICS

(Circuit of Figure 1. VIN = 15V, IOUT = 5μA, TA = 0°C to +85°C. Typical values are at TA = +25°C, unless otherwise noted.) (Note 1)

PARAMETER	SYMBOL	CONDITIONS	MIN	TYP	MAX	UNITS
Input Voltage Range	VIN		4		28	V
Supply Current (MAX8718)	IIN	SHDN = IN, TA = +25°C		12	18	μs
		SHDN = IN, VIN = 6V to 28V			25	μA
VCC Input Current (MAX8719)		0V < VCC < 2.7V, TA = +25°C	-0.1		+0.1	μA
		0V < VCC < 2.7V, TA = 0°C to +85°C		0.04		
VCC Input Current (MAX8718)		0V < VCC < 5.5V, TA = +25°C			3.4	μA
		0V < VCC < 5.5V, TA = 0°C to +85°C		2.3		
OUT Minimum Load Current					5	μA
Shutdown Supply Current		SHDN = 0V		1.2	3	μA
Dropout Supply Current		VOUT set to 5V, VIN = 4.7V		85		μA
OUT Output Voltage (MAX8718)		VIN = 6V to 28V, ILOAD = 1mA, 5/3 = GND, TA = +25°C	3.26	3.33	3.40	V
		VIN = 6V to 28V, ILOAD = 1mA, 5/3 = OUT, TA = +25°C	4.95	5.05	5.15	
		VIN = 6V to 28V, ILOAD = 5μA to 100mA, 5/3 = GND	3.15		3.48	
		VIN = 6V to 28V, ILOAD = 5μA to 100mA, 5/3 = OUT	4.75		5.25	
FB Threshold (MAX8719)	VFB	FB = OUT, VIN = 6V to 28V, ILOAD = 1mA	1.215	1.240	1.265	V
		FB = OUT, VIN = 6V to 28V, ILOAD = 5μA to 100mA (Note 2)	1.18		1.28	
FB Input Current (MAX8719)	IFB	VFB = 1.3V, TA = +25°C	-30		+30	nA
		VFB = 1.3V, TA = 0°C to +85°C		15		
5/3 Input Current (MAX8718)	I5/3	V5/3 = 5V, TA = +25°C	-30		+30	nA
		V5/3 = 5V, TA = 0°C to +85°C		2		
Dropout Voltage	VDROPOUT	ILOAD = 100mA (Note 3)			560	mV

高压、低功耗线性稳压器， 用于笔记本电脑

MAX8718/MAX8719

ELECTRICAL CHARACTERISTICS (continued)

(Circuit of Figure 1. $V_{IN} = 15V$, $I_{OUT} = 5\mu A$, $T_A = 0^\circ C$ to $+85^\circ C$. Typical values are at $T_A = +25^\circ C$, unless otherwise noted.) (Note 1)

PARAMETER	SYMBOL	CONDITIONS	MIN	TYP	MAX	UNITS
Output Current Limit	I_{LIM}	$V_{IN} = 6V$, $T_A = +25^\circ C$	210			mA
		$V_{OUT} = 0$, $V_{IN} = 6V$	125	340		
Output Reverse Leakage Current		V_{OUT} forced to 5.5V, $I_N =$ unconnected	70			μA
Capacitive Load Requirements		MAX8718	0.16			$\mu F/mA$
		MAX8719	0.23			
Startup Time Response		Rising edge of I_N or \overline{SHDN} to O_{UT} within spec limits, $C_{OUT} = 10\mu F$, $R_{LOAD} = 500\Omega$, $V_{OUT} = 5V$	1			ms
Startup Output Overshoot		$C_{OUT} = 10\mu F$, $R_{LOAD} = 500\Omega$, O_{UT} within 90% of the nominal output voltage	0.5			%
V_{CC} Threshold (MAX8718)		$T_A = +25^\circ C$, rising edge only	$0.88 \times V_{OUT}$	$0.9 \times V_{OUT}$	$0.92 \times V_{OUT}$	V
		$0^\circ C < T_A < +85^\circ C$, rising edge only	$0.85 \times V_{OUT}$	$0.9 \times V_{OUT}$	$0.95 \times V_{OUT}$	
V_{CC} Threshold (MAX8719)		$T_A = +25^\circ C$, rising edge only	$0.88 \times V_{FB}$	$0.9 \times V_{FB}$	$0.92 \times V_{FB}$	V
		$0^\circ C < T_A < +85^\circ C$, rising edge only	$0.85 \times V_{FB}$	$0.9 \times V_{FB}$	$0.95 \times V_{FB}$	
V_{CC} to PGOOD Delay		V_{TH} to $(V_{TH} - 100mV)$	4.5			μs
PGOOD Active-Timeout Period			100	185	300	ms
PGOOD Output Leakage Current		PGOOD = 5.5V, $V_{CC} = 5.5V$	0.1			μA
PGOOD Output Low Voltage		$I_{SINK} = 1.6mA$, $V_{CC} = GND$	0.3			V
V_{CC} Input Hysteresis			2			%
Thermal-Shutdown Threshold		$V_{\overline{SHDN}} = 0$ or 15V, $20^\circ C$ hysteresis	+165			$^\circ C$
\overline{SHDN} Input Low Voltage			0.25			V
\overline{SHDN} Input High Voltage			1.4			V
\overline{SHDN} Input Bias Current		$V_{\overline{SHDN}} = 0$ or 15V, $T_A = 0^\circ C$ to $+85^\circ C$	-1	+0.1	+1	μA

高压、低功耗线性稳压器， 用于笔记本电脑

MAX8718/MAX8719

ELECTRICAL CHARACTERISTICS

(Circuit of Figure 1 $V_{IN} = 15V$, $I_{OUT} = 5\mu A$, $T_A = -40^\circ C$ to $+85^\circ C$, unless otherwise noted.) (Note 4)

PARAMETER	SYMBOL	CONDITIONS	MIN	TYP	MAX	UNITS
Input Voltage Range	V_{IN}		4		28	V
Supply Current (MAX8718)	I_{IN}	$\overline{SHDN} = IN$, $V_{IN} = 6V$ to $28V$			25	μA
Supply Current (MAX8719)	I_{IN}	$\overline{SHDN} = IN$, $V_{IN} = 6V$ to $28V$			25	μA
OUT Minimum Load Current					5	μA
Shutdown Supply Current		$\overline{SHDN} = 0V$			3	μA
OUT Output Voltage (MAX8718)		$V_{IN} = 6V$ to $28V$, $I_{LOAD} = 5\mu A$ to $100mA$, $5/\sqrt{3} = GND$	3.10		3.48	V
		$V_{IN} = 6V$ to $28V$, $I_{LOAD} = 5\mu A$ to $100mA$, $5/\sqrt{3} = OUT$	4.72		5.25	
FB Threshold (MAX8719)	V_{FB}	FB = OUT, $V_{IN} = 6V$ to $28V$, $I_{LOAD} = 1mA$	1.215		1.265	V
		FB = OUT, $V_{IN} = 6V$ to $28V$, $I_{LOAD} = 5\mu A$ to $100mA$ (Note 2)	1.18		1.28	
FB Input Current (MAX8719)	I_{FB}	$V_{FB} = 1.3V$	-40		+40	nA
$5/\sqrt{3}$ Input Current (MAX8718)	$I_{5/\sqrt{3}}$	$V_{5/\sqrt{3}} = 5V$	-30		+30	nA
Dropout Voltage	$V_{DROPOUT}$	$I_{LOAD} = 100mA$ (Note 3)			560	mV
Output Current Limit	I_{LIM}	$V_{OUT} = 0$, $V_{IN} = 6V$	125		375	mA
Capacitive Load Requirements		MAX8718	0.16			$\mu F/mA$
		MAX8719	0.23			
Startup Time Response		Rising edge of IN or \overline{SHDN} to OUT within spec limits, $C_{OUT} = 10\mu F$, $R_{LOAD} = 500\Omega$, $V_{OUT} = 5V$			1	ms
V_{CC} Threshold (MAX8718)		$-40^\circ C < T_A < +85^\circ C$, rising edge only	$0.85 \times V_{OUT}$		$0.95 \times V_{OUT}$	V
V_{CC} Threshold (MAX8719)		$-40^\circ C < T_A < +85^\circ C$, rising edge only	$0.85 \times V_{FB}$		$0.95 \times V_{FB}$	V
PGOOD Active-Timeout Period			100		300	ms
PGOOD Output Low Voltage		$I_{SINK} = 1.6mA$, $V_{CC} = GND$			0.3	V
\overline{SHDN} Input Low Voltage					0.25	V
\overline{SHDN} Input High Voltage			1.4			V
\overline{SHDN} Input Bias Current		$V_{\overline{SHDN}} = 0$ or $15V$, $T_A = -40^\circ C$ to $+85^\circ C$	-1		+1	μA

Note 1: Limits are 100% production tested at $T_A = +25^\circ C$. Limits over the operating temperature range are guaranteed through correlation using standard quality control (SQC) methods.

Note 2: Pulse test at $V_{IN} = 28V$, $I_{OUT} = 100mA$ to avoid exceeding package power-dissipation limits.

Note 3: Dropout voltage is tested by reducing the input voltage until V_{OUT} drops to 100mV below its nominal value as measured with V_{IN} starting 2V above V_{OUT} .

Note 4: Specifications to $-40^\circ C$ are guaranteed by design, not production tested.

高压、低功耗线性稳压器， 用于笔记本电脑

典型工作特性

(Circuit of Figure 1. $V_{IN} = 15V$, $V_{OUT} = 3.3V$, $T_A = +25^\circ C$, unless otherwise noted.)

MAX8718/MAX8719

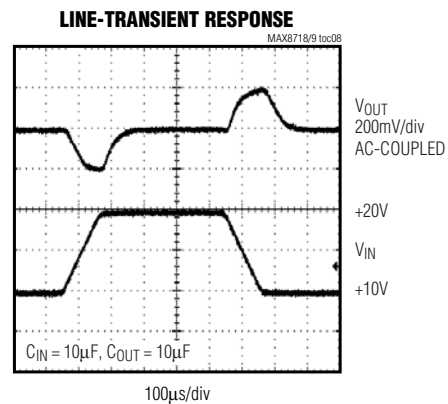
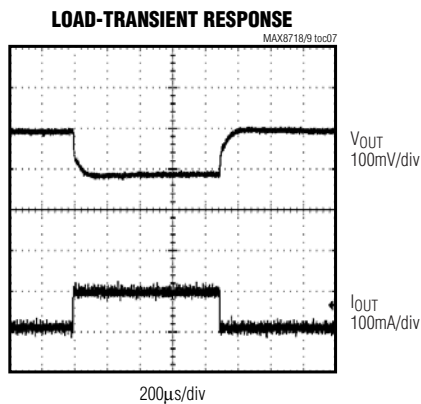
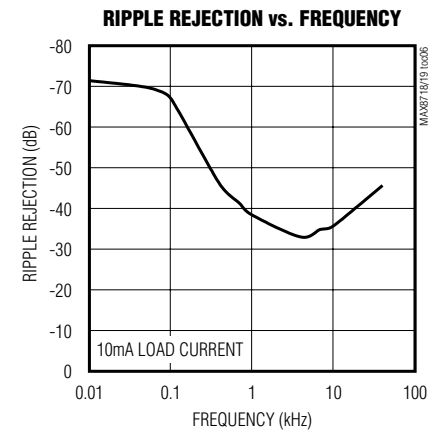
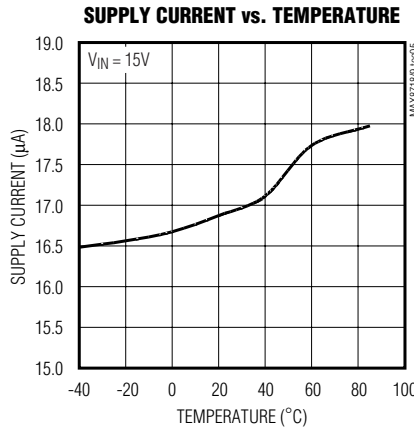
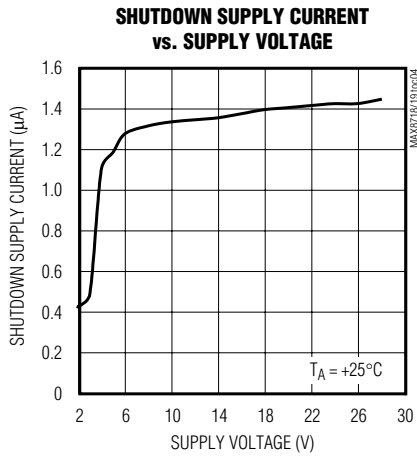
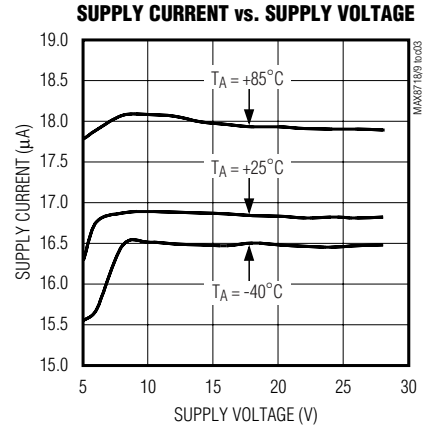
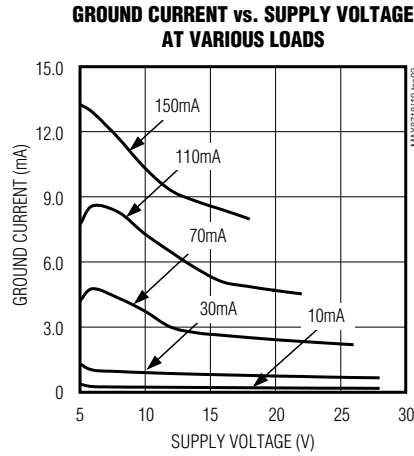
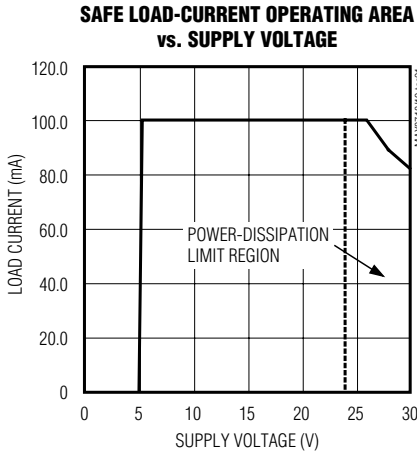

高压、低功耗线性稳压器， 用于笔记本电脑

典型工作特性 (续)

(Circuit of Figure 1. $V_{IN} = 15V$, $V_{OUT} = 3.3V$, $T_A = +25^\circ C$, unless otherwise noted.)

TIME TO EXIT SHUTDOWN

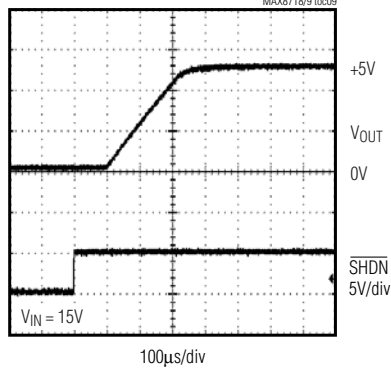

DROPOUT SUPPLY CURRENT vs. SUPPLY VOLTAGE

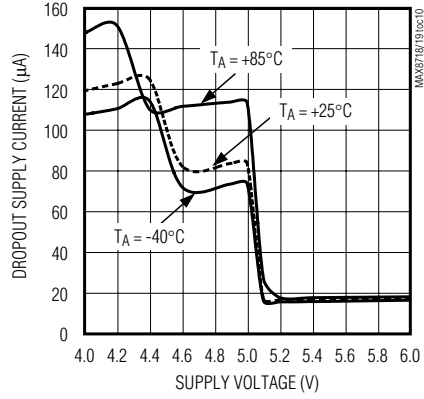

DROPOUT VOLTAGE vs. LOAD CURRENT

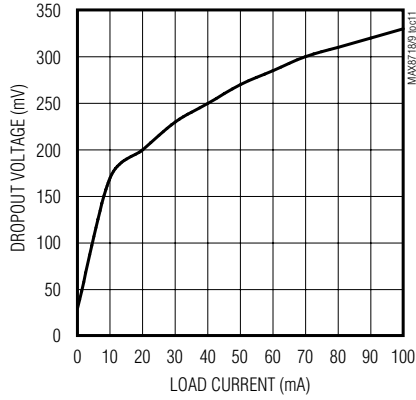

PGOOD TRANSIENT RESPONSE

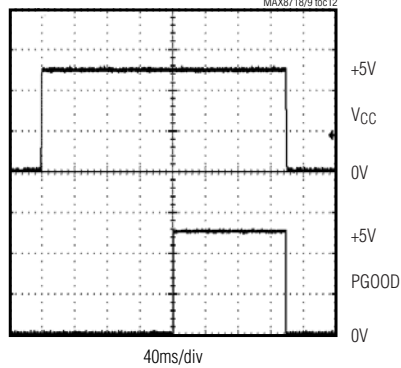

PGOOD ACTIVE-TIMEOUT PERIOD vs. TEMPERATURE

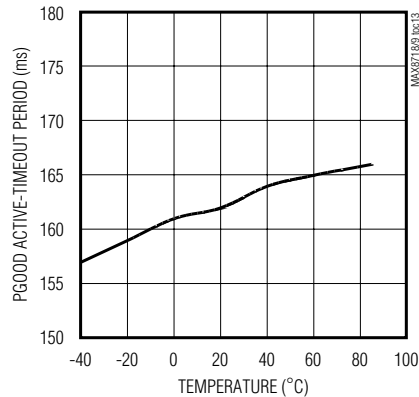

高压、低功耗线性稳压器， 用于笔记本电脑

引脚说明

MAX8718/MAX8719

引脚		名称	功能
MAX8718	MAX8719		
1	1	IN	正电源输入，连接到 +4V 至 +28V 电源。
2	2	GND	地
3	—	5/3	输出电压选择输入，将 5/3 接 GND 选择 3.3V 输出，或接 OUT 选择 5V 输出。
—	3	FB	反馈输入，稳定在 1.24V 标称值。
4	4	V _{CC}	PGOOD 检测输入。
5	5	PGOOD	电源就绪输出。
6	6	$\overline{\text{SHDN}}$	关断控制输入。
7	7	I.C.	内部连接。该引脚已在内部连接，用于测试；应用中该引脚保持悬空。
8	8	OUT	100mA 稳压器输出。



图 1. MAX8718 典型工作电路



图 2. MAX8719 典型工作电路

详细说明

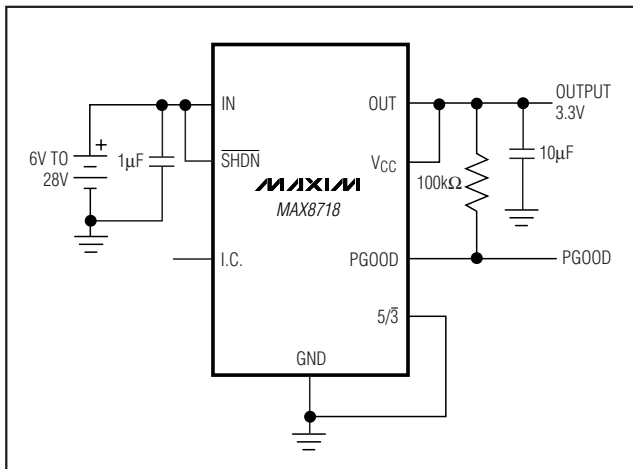
MAX8718/MAX8719 低静态电流线性稳压器主要为高输入电压应用而设计。MAX8718 能为高达 100mA 的负载提供预置的 3.3V 或 5.0V 电压输出 (图 1)。MAX8719 提供一个 1.24V 至 28V 的可调输出 (图 2)。在给定温度下，最大输出电流是封装最大功率耗散的函数。需要一个 5μA 的负载电流维持输出稳定。

MAX8718 的输出电压通过一个接至 OUT 的内部电阻分压器反馈，利用 5/3 引脚将输出电压设定为 5.0V 或 3.3V。将 5/3 引脚接 OUT 选择 5V 输出，或将 5/3 引脚接 GND 选择 3.3V 输出。

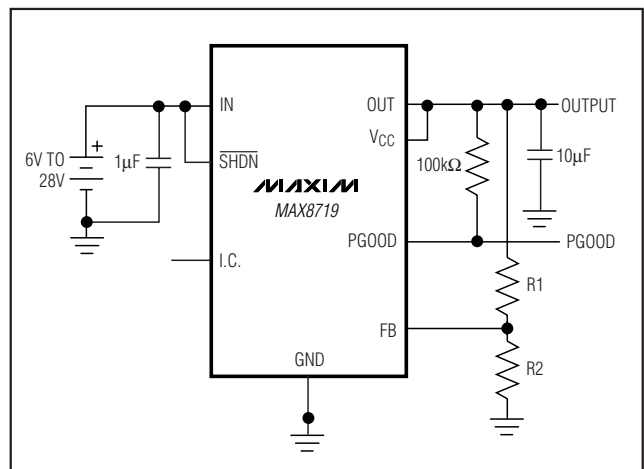
MAX8719 的输出通过一个外部电阻分压器进行调节。典型的反馈门限电压为 1.24V (见设置 MAX8719 输出电压部分)。MAX8718/MAX8719 功能框图如图 3 所示。

关断

当 $\overline{\text{SHDN}}$ 为低时，器件进入关断模式。关断模式下，内部 pnp 功率晶体管、控制电路、基准和所有的偏置电路都关闭，电源电流降至 3μA 以下。将 $\overline{\text{SHDN}}$ 接 IN 可实现自动启动。

高压、低功耗线性稳压器， 用于笔记本电脑



图 3. MAX8718/MAX8719 功能框图

电流限制

输出电流限制在 210mA (典型值)。电流限制值大于 100mA (最小) 安全工作电流。输出可以对地短路 30 秒而不会损坏器件。

热过载保护

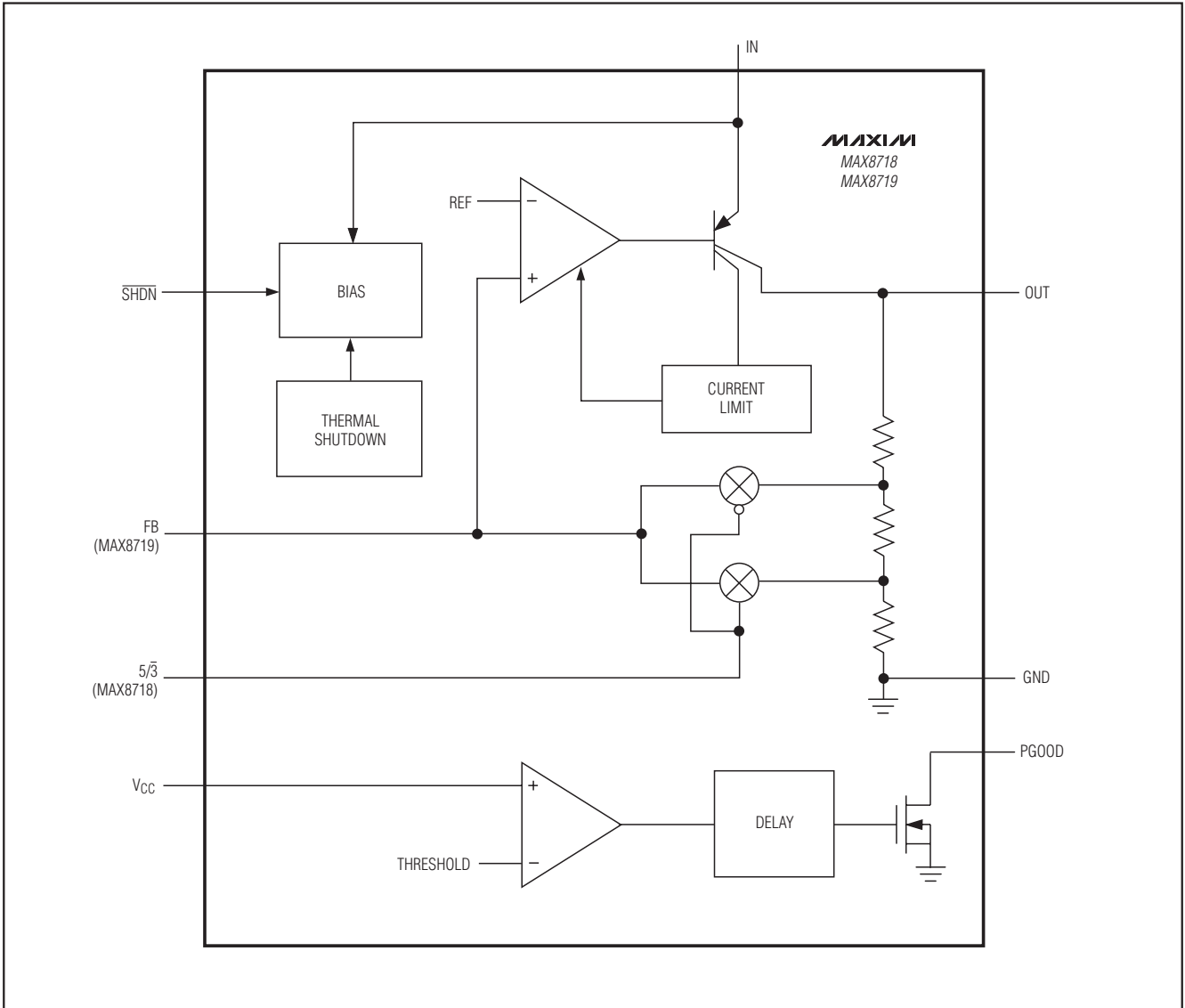
当结温超过 $T_j = +165^{\circ}\text{C}$ 时，内部温度传感器向关断逻辑电路发送信号，并关闭调整管以使 IC 冷却。IC 结温降低

20°C (典型值) 后，温度传感器再次打开调整管，在连续热过载条件下输出为间歇开关状态。

工作区域和功耗

所允许的最大功耗依赖于管壳和电路板间的热阻、管芯和环境温差以及空气流动速度等。器件的功耗为 $P = I_{\text{OUT}} \times (V_{\text{IN}} - V_{\text{OUT}})$ 。环境温度为 +70°C 时的最大耗散功率为 1951mW (见 *Absolute Maximum Ratings* 部分)。TDFN 封装的管芯-管壳热阻为 41°C/W，最高安全结温为 +150°C。

高压、低功耗线性稳压器， 用于笔记本电脑



图4. 大电流通道的布局

GND引脚和底部焊盘提供对地的电气连接和封装散热通道双重功能。使用金属走线或地层将GND和底部焊盘接地。封装的总热阻与连接器件的PC板覆铜区域面积成反比关系。要达到额定的热阻，至少要有650mm²的覆铜区域与MAX8718/MAX8719的管壳相连。

应用信息

设置MAX8719输出电压

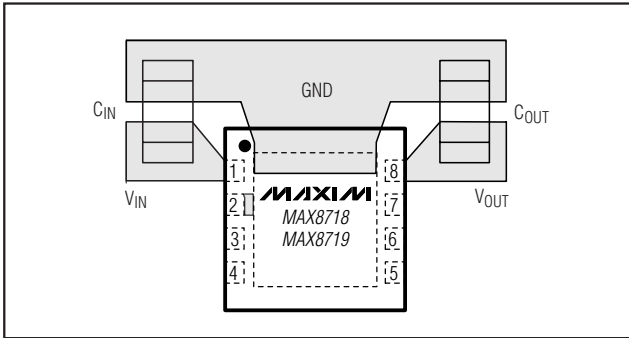
使用一个电阻分压器(图3中的R1和R2)来设置MAX8719的输出电压。选择R2 = 125kΩ或更小的阻值，从而在OUT端维持10μA的最小负载电流。使用以下公式计算R1:

$$R1 = R2 \times \left(\frac{V_{OUT}}{V_{FB}} - 1 \right)$$

其中V_{FB} = 1.24V (典型值)。

电容选择

在输入端使用一个0.1μF(最小值)的电容。更大的电容值有助于改善输入电源瞬态响应。

在输出端使用一个1μF(最小值)的电容，或在100mA负载电流情况下使用一个15μF电容。也可以使用一个1μF加上0.16μF/mA(MAX8719为0.23μF/mA)的电容。当输出电压小于3.3V时，使用15μF电容替代10μF电容。要实现稳定工作，输出电容的等效串联电阻(ESR)必须小于1Ω。

输出电压噪声

正常工作时，MAX8718/MAX8719的典型噪声为5mV_{p-p}。这在大多数应用中是可以忽略的。在具有分辨率高于12

位的模数转换器(ADC)的应用中，要考虑ADC的电源抑制参数。

瞬态响应

典型工作特性给出了MAX8718/MAX8719的负载瞬态响应。当负载电流发生跃变时，稳压器的响应由两部分构成：由于输出电容ESR和稳压器输出阻抗的存在，在输出电压上会产生一个瞬间的跃变；另一缓慢过程是稳压器对输出电压的修正过程。OUT负载电流从10mA跃变到20mA时，输出电压会产生20mV的瞬态变化。

电源就绪输出(PGOOD)

MAX8718/MAX8719包括一个独立的电源就绪监视器，该监视器的检测输入(V_{CC})，可以接至稳压器的输出或相近的电压上。在MAX8718中，比较器的门限值会根据5/3引脚的状态跟踪输出设定值。在MAX8719中，比较器的门限设置为反馈基准电压。当V_{CC}超过稳压设定值的90%时，PGOOD输出变高。输出进入稳压状态时有一个固定的100ms(最小值)延时，这有助于确保输出电压稳定下来。偏离稳压状态时，PGOOD延时要快的多，即4.5μs(典型值)，促使系统尽可能快地对非稳压条件做出反应。

电源就绪监视器具有漏极开路输出，可从外部上拉至OUT。PGOOD的电压额定值为28V。

布局指南

良好的布局对于降低噪声影响、确保精确稳压十分重要。对于大电流通道要使用合适的线宽，并保持较短的连线以减小寄生电感和电容。图4给出了一个大电流通道的布局。旁路电容应靠近IN和OUT引脚放置。当使用MAX8719时，反馈电阻应该靠近器件放置，以避免地层的电位差可能引起的输出电压变化。底部裸露焊盘要与尽可能大的覆铜区域连接。

芯片信息

TRANSISTOR COUNT: 1298

PROCESS: BiCMOS

高压、低功耗线性稳压器， 用于笔记本电脑

封装信息

(本数据资料提供的封装图可能不是最近的规格，如需最近的封装外型信息，请查询 www.maxim-ic.com.cn/packages。)

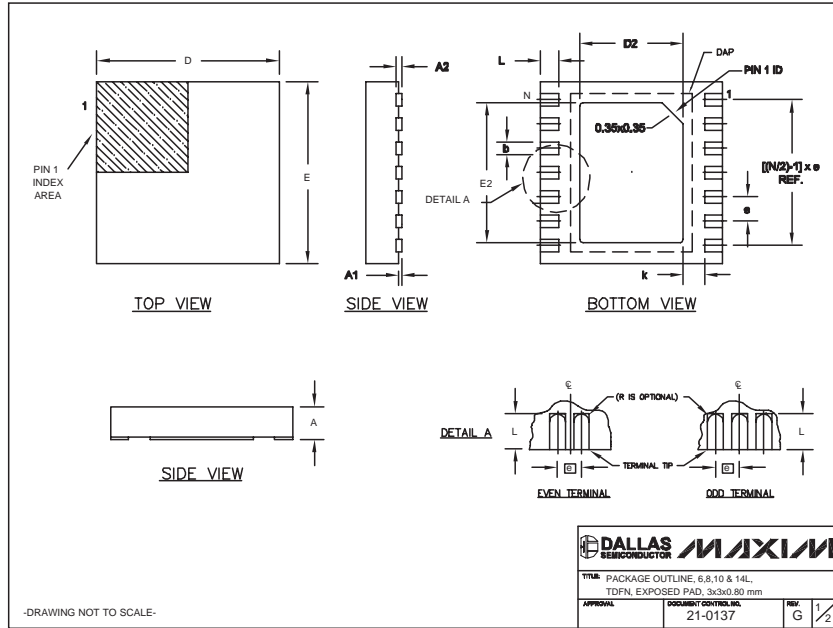

COMMON DIMENSIONS							
SYMBOL	MIN.	MAX.					
A	0.70	0.80					
D	2.90	3.10					
E	2.90	3.10					
A1	0.00	0.05					
L	0.20	0.40					
k	0.25 MIN.						
A2	0.20 REF.						

PACKAGE VARIATIONS							
PKG. CODE	N	D2	E2	e	JEDEC SPEC	b	[(N/2)-1] x e DOWNBONDS ALLOWED
T633-1	6	1.50±0.10	2.30±0.10	0.95 BSC	MO229 / WEEA	0.40±0.05	1.90 REF. NO
T633-2	6	1.50±0.10	2.30±0.10	0.95 BSC	MO229 / WEEA	0.40±0.05	1.90 REF. NO
T833-1	8	1.50±0.10	2.30±0.10	0.65 BSC	MO229 / WEEC	0.30±0.05	1.95 REF. NO
T833-2	8	1.50±0.10	2.30±0.10	0.65 BSC	MO229 / WEEC	0.30±0.05	1.95 REF. NO
T833-3	8	1.50±0.10	2.30±0.10	0.65 BSC	MO229 / WEEC	0.30±0.05	1.95 REF. YES
T1033-1	10	1.50±0.10	2.30±0.10	0.50 BSC	MO229 / WEED-3	0.25±0.05	2.00 REF. NO
T1433-1	14	1.70±0.10	2.30±0.10	0.40 BSC	----	0.20±0.05	2.40 REF. YES
T1433-2	14	1.70±0.10	2.30±0.10	0.40 BSC	----	0.20±0.05	2.40 REF. NO

NOTES:

- ALL DIMENSIONS ARE IN mm, ANGLES IN DEGREES.
- COPLANARITY SHALL NOT EXCEED 0.08 mm.
- WARPAGE SHALL NOT EXCEED 0.10 mm.
- PACKAGE LENGTH/PACKAGE WIDTH ARE CONSIDERED AS SPECIAL CHARACTERISTIC(S).
- DRAWING CONFORMS TO JEDEC MO229, EXCEPT DIMENSIONS "D2" AND "E2", AND T1433-1 & T1433-2.
- "N" IS THE TOTAL NUMBER OF LEADS.
- NUMBER OF LEADS SHOWN ARE FOR REFERENCE ONLY.

DALLAS SEMICONDUCTOR **MAXIM**

TITLE: PACKAGE OUTLINE, 6,8,10 & 14L,
TDFN, EXPOSED PAD, 3x3x0.80 mm

APPROVAL: DOCUMENT CONTROL NO. 21-0137 REV. G 2/2

-DRAWING NOT TO SCALE-

Maxim 不对 Maxim 产品以外的任何电路使用负责，也不提供其专利许可。Maxim 保留在任何时间、没有任何通报的前提下修改产品资料和规格的权利。

10 **Maxim Integrated Products, 120 San Gabriel Drive, Sunnyvale, CA 94086 408-737-7600**